

SDR-DSP-IO-IQ-DIFF (-1)

- 1 Index
- 2 DSP interface connector, PCB dimensions, fixing points
- 3 DAC
- 4 ADC
- 5 Power

Copyright (c) Matti Aarnio OH2MQK

sdr-dsp-io-iq-diff
8/10/2005 00:23:01
Sheet: 1/5

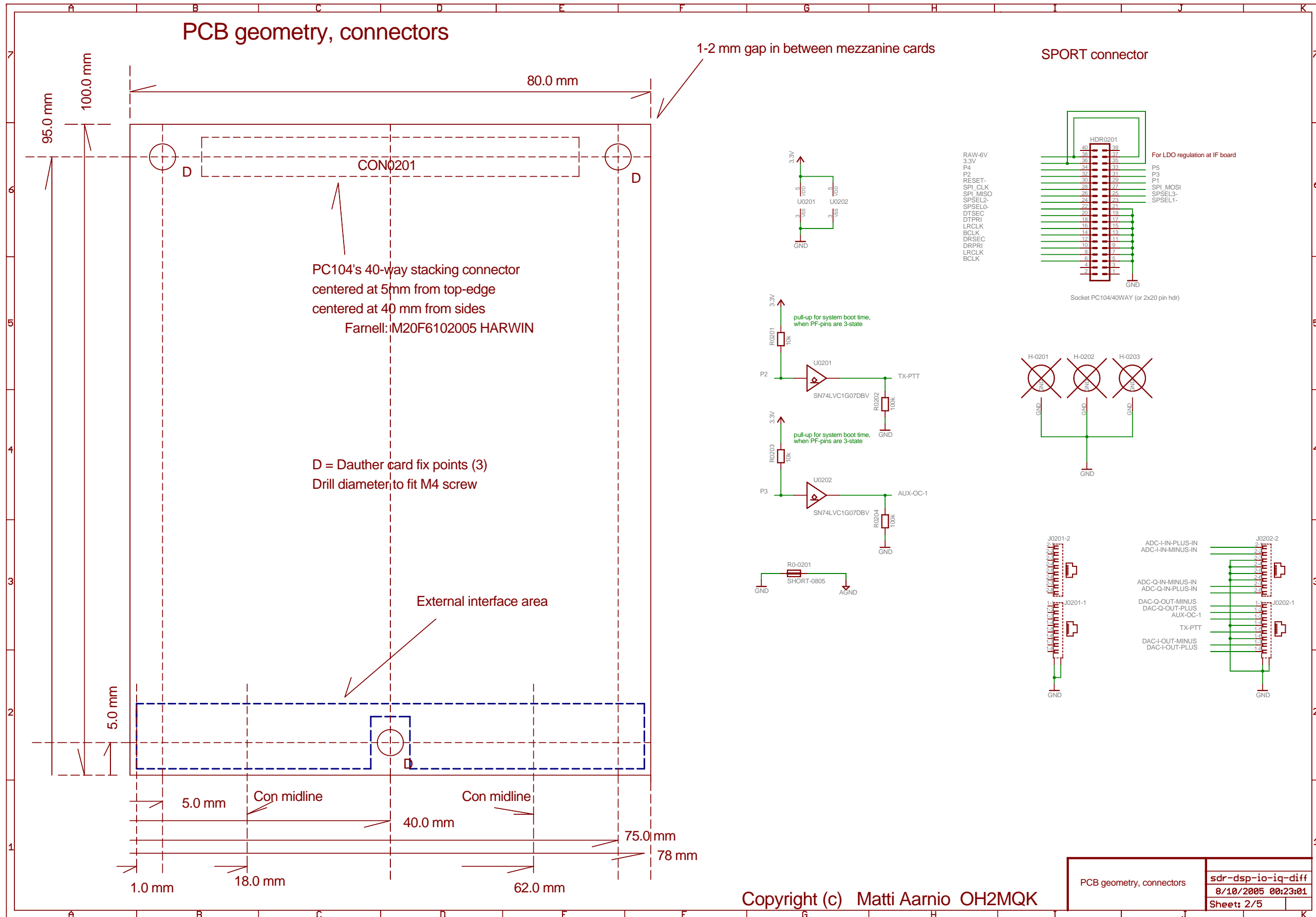

Copyright (c) Matti Aarnio OH2MQK

PCB geometry, connectors	sdr-dsp-io-iq-diff
	8/10/2005 00:23:01
	Sheet: 2/5

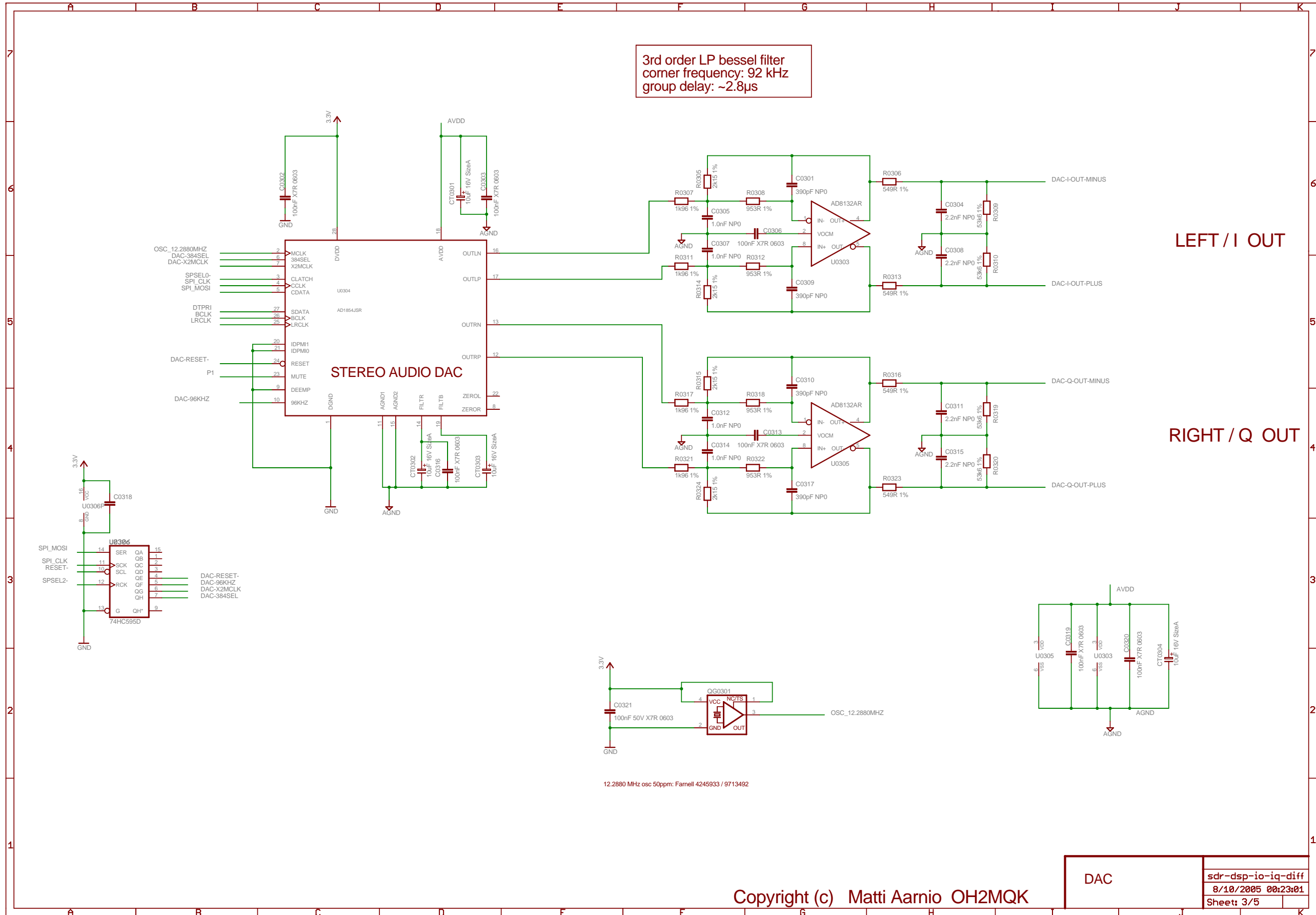

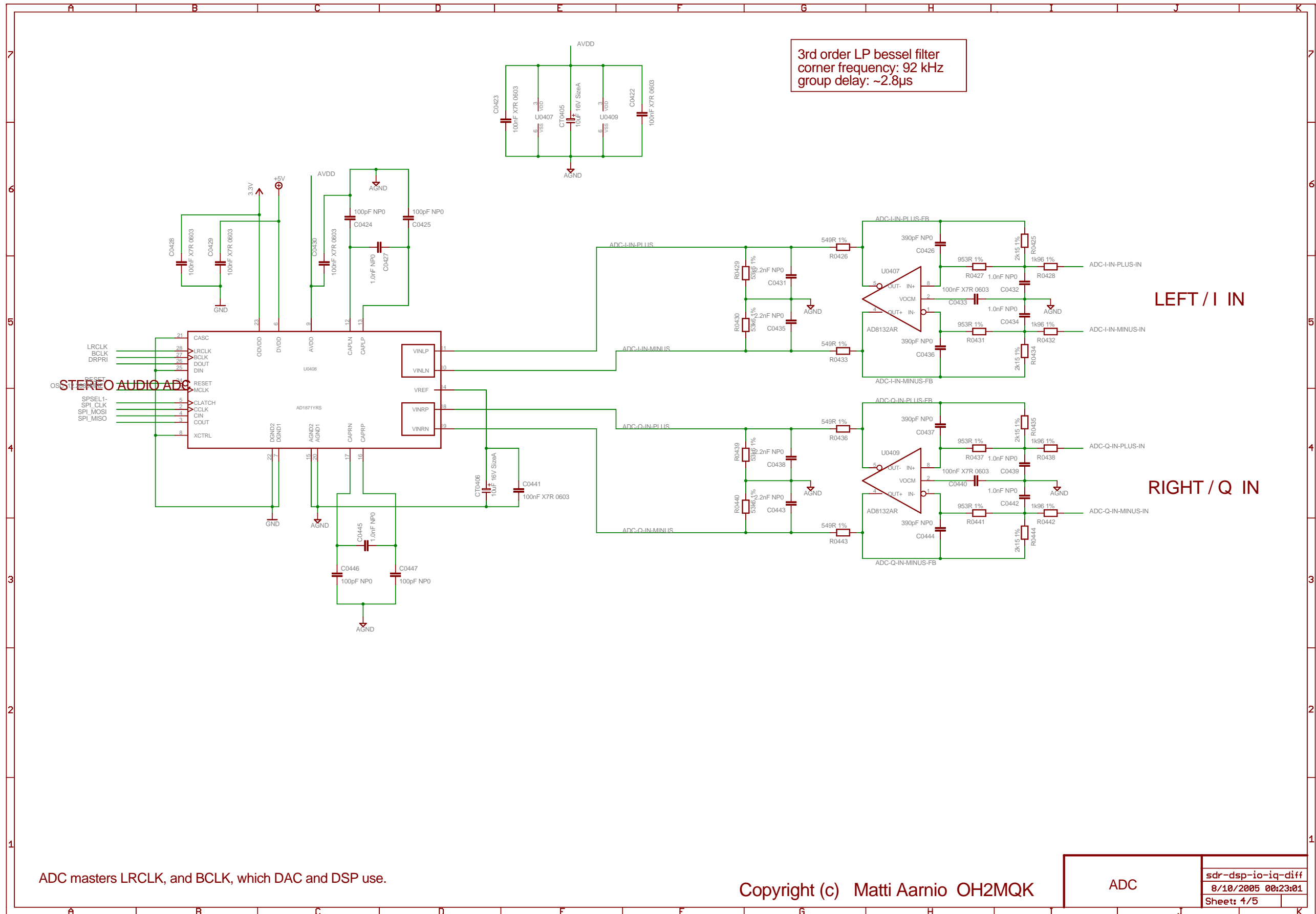

FIX FEEDBACK RESISTOR VALUES!

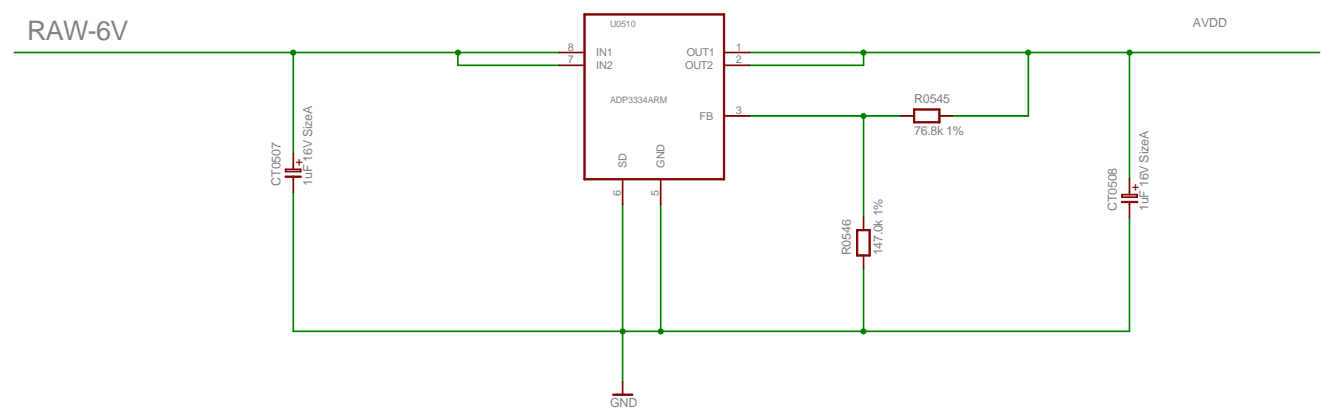

FIX FEEDBACK RESISTOR VALUES!

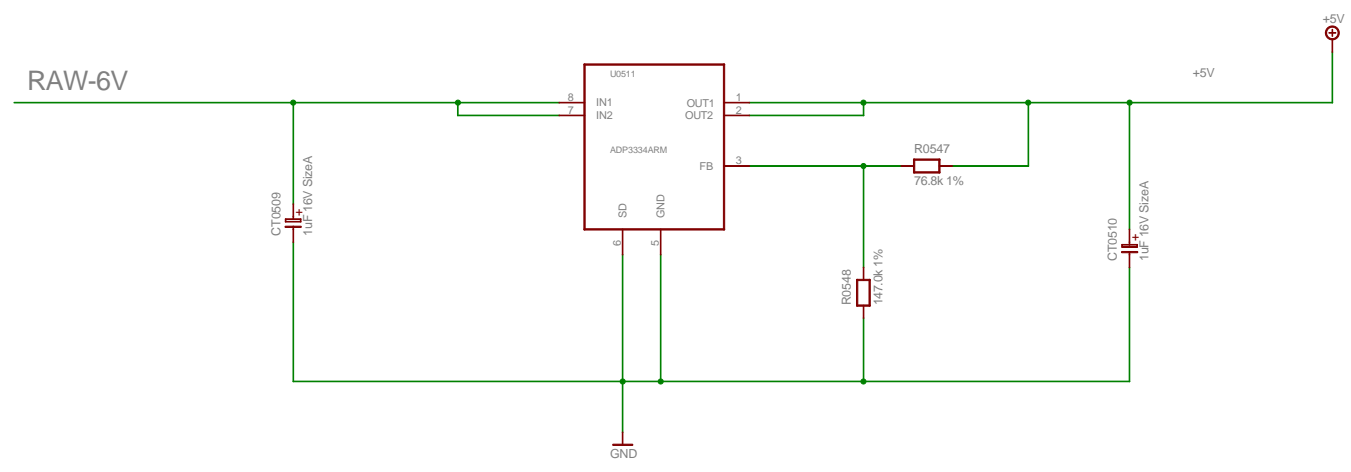

Copyright (c) Matti Aarnio OH2MQK

Power	sdr-dsp-io-iq-diff
	8/10/2005 00:23:01
	Sheet: 5/5